

序号	变更说明	变更人	变更日期
1	LOGO 变更；取消电话号码。	黄东果	04/16/2013

WAC LIGHTING
Responsible Lighting®

安装说明: LED STEP AND WALL LIGHTS
型号: WL100-LD05E

注意:

- 安装前请完整阅读说明书。
- 灯具系统需由有资格的专业电工安装，并符合国家和地方的法律法规。
- 为了减少火灾，触电和人员受伤的危险，在安装或修改系统前，必须关闭电源总开关。
- 请保留本说明书用于将来维护作参考。
- 不按说明书安装灯具而出现的故障，将没有质量保证。

安装方法:

接线盒:开口尺寸为 119X74mm。防水接头通过的防水电源线直径为φ 6-8mm。

1. 室外安装接线盒，必须保证其密封，不漏水。
2. 用两个螺丝将支架安装在接线盒上面，如图 1 所示。
3. 去除密封垫圈表面隔离纸，将其粘在灯具的背面（如图 2 所示）。
注意: 室内安装, 可以不用密封垫圈。
4. 灯具与接线盒电线连接如下：灯具黑色连接线接火线，白色连接线接零线，黄绿色连接线接地线（如图 3 所示）。
注意: 可以多个灯具（多达 200）并联使用。
5. 将所有的电线与连接端子放入到接线盒内再安装灯具。
注意: 在室外安装时, 需要保持安装位置干燥, 为了防止灯具内部渗水, 必须使用室外防水硅胶（GE RTV-162 或其它同规格产品）填充在灯具背面密封垫圈与安装表面之间的缝隙里。
6. 灯具在出厂时会预先将两个橡胶垫圈安装在两个螺丝孔的表面（如图 4 所示）。
（注: WAC 提供灯具, 安装支架, 密封垫圈, 安装螺丝, 橡胶垫圈）。

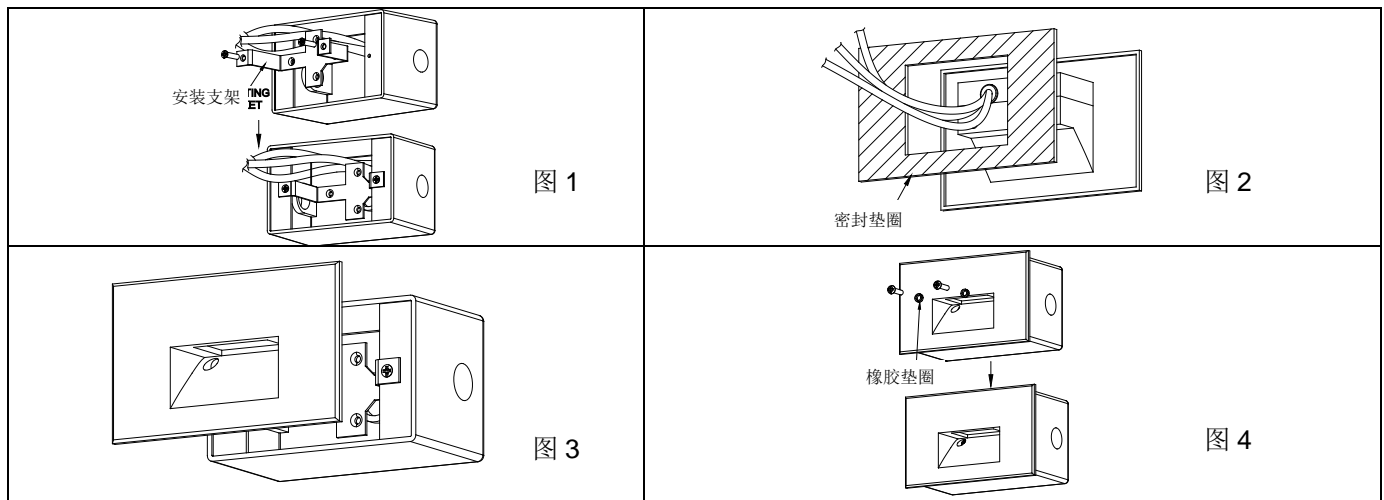

WAC LIGHTING

由“WAC” “Responsible Lighting” 商标持有人美国 WAC Lighting 公司授权
 中国营销 : 华格照明灯具（上海）有限公司
 总部地址 : 上海市张江毕升路 299 弄第一上海中心 14 号楼（邮编 201204）
 中国工厂 : 东莞华明灯具有限公司出品
 地址 : 广东省东莞市清溪镇清风路 390 号（邮编 523653）

IMPORTANT:

- Read all instructions before installing.
- System is intended for installation by a qualified electrician in accordance with the National Electric Code, and local regulations. Consult with local inspector to ensure compliance.
- To reduce the risk of fire, electrical shock and injuries to persons, turn off power at main switch before installing or modifying the system.
- Retain instructions for future maintenance reference.
- Not complying with instructions could result in failure of the fixtures, and void the warranty.

INSTALLATION:

Junction box: The dug hole size is 119 X 74 mm, The waterproof connector allows ϕ 6-8mm waterproof power cord.

1. Remove the release paper on gasket, paste gasket onto the back of the fixture (Fig.2).
2. Secure mounting bracket to J-box using (2) 8-32 J-Box screws (J-box and screws by others) as shown in Fig.1.
3. Removing the release paper in gasket, insert gasket onto the back of the fixture (Fig.2).
Note: For indoor installation, gasket is not required, and can be discarded.
4. Connect the fixture wires to the junction box wires as follows: Black fixture wire to black (Hot) J-BOX wire, white fixture wire to white (Neutral) J-box wire, and yellow-green fixture wire to Ground. (See Fig.3)
Note: Multiple fixtures (up to 200) can be wired together in parallel: Hot to hot, and neutral to neutral.
5. Place all wiring and connectors back in junction box and install the fixture.
Note: For outdoor installation, it is recommended that the installer run a bead of clear, outdoor-rated silicone (GE RTV-162 or equivalent, provided by others) caulk between gasket or back of fixture and mounting surface to prevent seepage of water into fixture.
6. Secure the fixture to the surface using two mounting screws and two rubber washers pre-installed at the factory. (Fig.4). (Note: Fixture, mounting bracket, gasket, mounting screws, and rubber washers provided by WAC.)

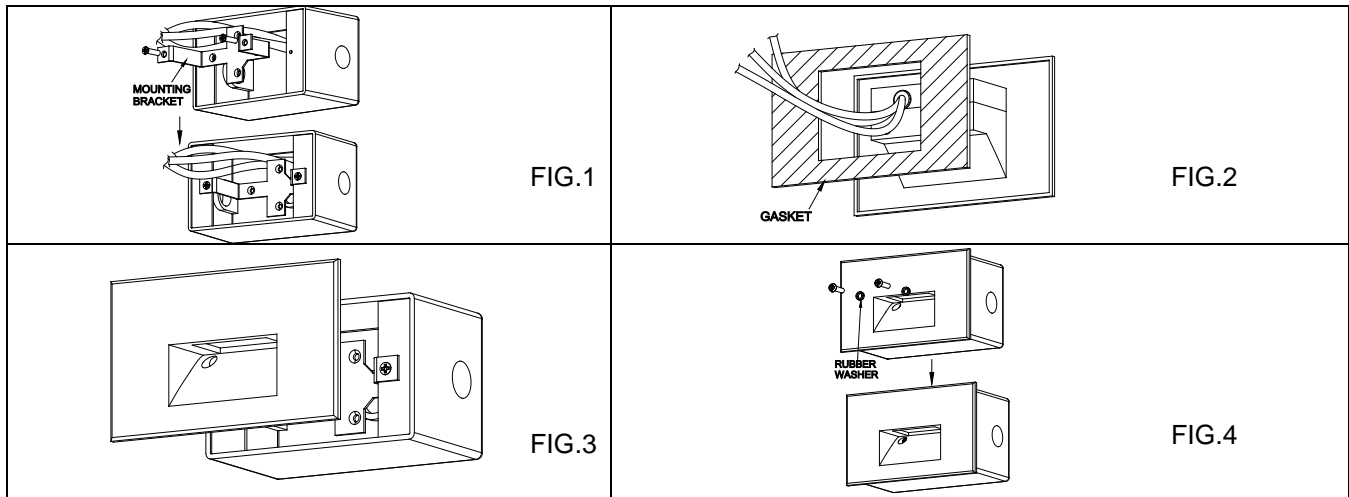

WAC LIGHTING

“WAC” “Responsible Lighting” trademarks holder is WAC Lighting Co., Ltd which authorizes other firms to use trademarks.

Address : WAC Lighting (Shanghai) Co., Ltd.
 China sale headquarter : No.14, Lane 299, Bi Sheng Road, Zhang Jiang, Pu Dong District, Shanghai China 201204
 China factory : WAC Lighting (Dongguan) Co., Ltd.
 Address : No.390, Qing Feng Road, Qing Xi Town, Dongguan City, Guangdong Province, China 523653

料号: 7DDI000625

规格: 80 克进口书写纸 A4, 短边对折两次, 双面印刷

图号: WL100-01B

设计: 杜林 10/10/2012

审核:

标准化:

批准:

2/2